

KITCHEN COLLECTION



ZECCHINON

100%
MADE
IN
ITALY

Kitchen collection

ZECCHINON

Contents

05. A FAMILY COMPANY

06. DESIGN MOODS

T80

T70

FRAME 1.5

KATE

KELLY

ISABEL

ALEXIA

K105

100. TIMELESS MOODS

FRAME 1.5

FRAME 5.0

140. ELEMENTI SPECIALI

162. MATERIALI

A family company

The strenght of a family tradition looking to the future.

Since 1948, three generations have shaped kitchens designed to last and evolve, a true expression of excellence and timeless beauty, inspired by the spirit of Made in Italy.

La forza di una tradizione familiare che guarda al futuro.

Da 1948, tre generazioni danno forma a cucine pensate per durare ed evolversi. Una vera espressione dell'eccellenza e della bellezza senza tempo del Made in Italy.

FR_La force d'une tradition familiale tournée vers l'avenir.
Depuis 1948, trois générations façonnent des cuisines conçues pour durer et évoluer, véritable expression de l'excellence et de la beauté intemporelle du Made in Italy.

Since 1949



T80 / T70 FRAME 1.5 KATE / KELLY / ISABEL / ALEXIA K105

Una collezione vasta e articolata,

capace di abbracciare estetiche diverse con coerenza e identità, dove modelli, materiali e finiture dialogano con naturalezza. Un insieme completo che permette di creare ambienti unici, armoniosi e sempre personali.

EN_ **A wide and articulate collection,** capable of embracing different aesthetics with coherence and identity, where models, materials and finishes interact naturally. A complete offering that allows you to create unique, harmonious and truly personal spaces.

FR_ **Une collection vaste et articulée,** capable d'embrasser des esthétiques diverses avec cohérence et identité, où modèles, matériaux et finitions dialoguent naturellement. Un ensemble complet qui permet de créer des espaces uniques, harmonieux et véritablement personnels.

T80

Progetto innovativo ed esclusivo, le ante spessore 12 mm realizzate con la tecnologia in alveolare di alluminio, sono estremamente leggere e resistenti alla flessione.

EN_ Innovative and exclusive project, the 12 mm thick doors made with aluminium honeycomb technology, are extremely light and resistant to bending.

FR_ D'un design innovant et exclusif, les portes de 12 mm d'épaisseur réalisées avec la technologie alvéolaire en aluminium sont extrêmement légères et résistantes à la flexion.

Sistemi di apertura

Opening system / Système d'ouverture

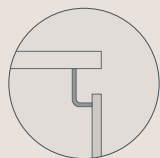

Gola Systemkappa
Systemkappa Groove
Gorge Systemkappa

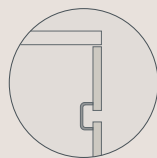

Gola intermedia
Middle Groove
Gorge intermédiaire

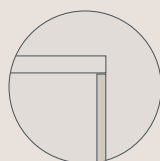

Maniglia
Handle
Poignée

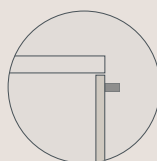

Push-pull
Push-pull handle
Push-pull





Finiture

Laccato Opaco Cashmere
 Larice Amber
 Laminam Terra di Matera

Finishes

Matt Lacquered Camelia
 Larch Amber
 Laminam Terra di Matera

Finitions

Laqué Mat Camelia
 Mèlèze Amber
 Laminam Terra di Matera



Finiture
 Metallo Satinato Dark Bronze
 Rovere Castoro
 Marmo Rosso Lepanto

Finishes
 Satin Matel Dark Bronze
 Oak Veneer Castoro
 Marble Rosso Lepanto

Finitions
 Métal Satiné Dark Bronze
 Chêne Castoro
 Marbre Rosso Lepanto

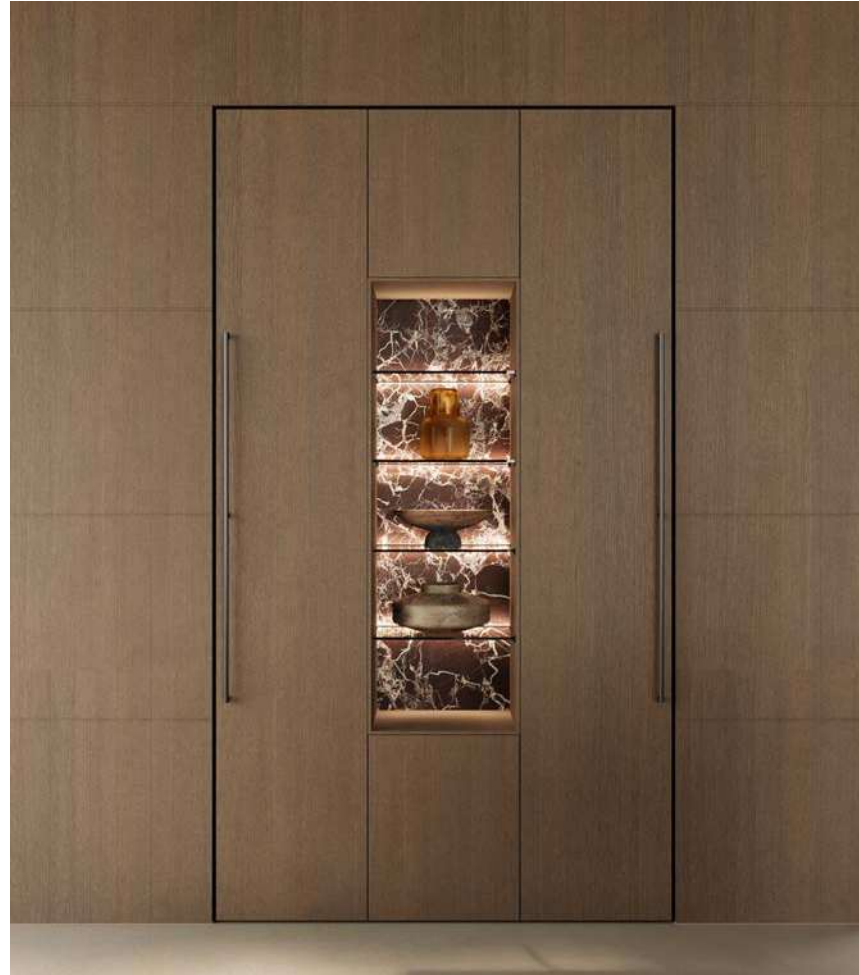





Finiture
 Metal Raw Mr1 Ferro
 Rovere Termocotto
 Dekton Entzo

Finishes
 Metal Raw Mr1 Ferro
 Heat-Treated Oak
 Dekton Entzo

Finitions
 Metal Raw Mr1 Ferro
 Chêne Termocotto
 Dekton Entzo





T70

Un telaio in alluminio che supporta svariati materiali quali la preziosa e naturale ceramica, il vetro, le essenze e molto altro, liberando così le più sofisticate fantasie progettuali.

EN_ An aluminium frame that supports various materials such as precious and natural ceramics, glass, wood and much more, thus making way for the most sophisticated design imagination.

FR_Un cadre en aluminium qui supporte une variété de matériaux tels que des matériaux précieux, des céramiques naturelles, du verre, du bois et bien d'autres encore, libérant ainsi les fantasies de conception les plus sophistiquées.

Sistemi di apertura

Opening system / Système d'ouverture

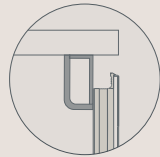

Gola Systemline
Systemline Groove
Gorge Systemline

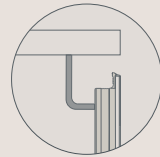

Gola Systemkappa
Systemkappa Groove
Gorge Systemkappa

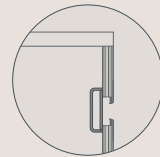

Gola intermedia
Middle Groove
Gorge intermédiaire

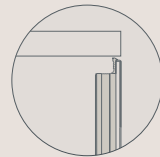

Push-pull
Push-pull handle
Push-pull

FINITURE TELAIO

frame finishes / finitions du cadre



Nero



Champagne





Finiture
 Fenix Ntm Beige Arizona
 Larice Arctic
 Laminam Diamond Cream

Finishes
 Fenix Ntm Beige Arizona
 Larch Arctic
 Laminam Diamond Cream

Finitions
 Fenix Ntm Beige Arizona
 Mèlèze Arctic
 Laminam Diamond Cream



VA E VIENI

Trasforma l'anta di una colonna in una porta passante bidirezionale, integrata con continuità nella zona colonne della cucina.



EN_ Va e Vieni transforms a tall-unit door into a bidirectional passage door, seamlessly integrated into the kitchen column area.

FR_Va e Vieni transforme la porte d'une colonne en une porte passante bidirectionnelle, parfaitement intégrée à l'ensemble des colonnes de la cuisine.

FLEX

Una boiserie ricca di soluzioni e materiali, un piccolo mondo da progettare con piacere, illuminato da luci e accessori che ne esaltano la profondità e il carattere.



EN_ A boiserie rich in solutions and materials, a small world to design with pleasure, illuminated by lights and accessories that enhance its depth and character.

FR_ Une boiserie riche en solutions et en matériaux, un petit univers à concevoir avec plaisir, éclairé par des jeux de lumière et des accessoires qui en soulignent la profondeur et le caractère.



Finiture

Castagno Fumo
Dekton Morpheus

Finishes

Chestnut Fumo
Dekton Morpheus

Finitions

Chataignier Fumo
Dekton Morpheus





FRAME 1.5

Si presenta come una celebrazione dell'equilibrio formale, dove ogni dettaglio parla di ordine e precisione. Una cornice perimetrale sottile, di appena 14 mm, contorna con discrezione ma decisione l'intera struttura, conferendo un senso di rigore e armonia visiva.

EN. **FRAME 1.5** is a celebration of formal balance, where every detail speaks of order and precision. A thin perimeter frame, just 14 mm wide, discreetly yet decisively outlines the entire structure, conveying a sense of rigor and visual harmony.

FR. **FRAME 1.5** se présente comme une célébration de l'équilibre formel, où chaque détail évoque l'ordre et la précision. Un cadre périphérique fin, d'à peine 14 mm, entoure avec discrétion mais détermination l'ensemble de la structure, conférant un sentiment de rigueur et d'harmonie visuelle.

Sistemi di apertura

Opening system / Système d'ouverture

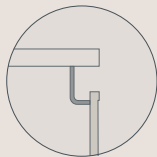

Gola Systemkappa
Systemkappa Groove
Gorge Systemkappa

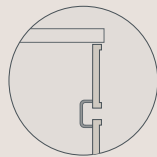

Gola intermedia
Middle Groove
Gorge intermédiaire

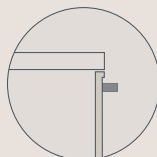

Maniglia
Handle
Poignée

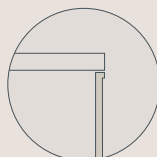

Push-pull
Push-pull handle
Push-pull





Finiture
Castagno Gold
MDI Inalco Meteora

Finishes
Chestnut Gold
MDI Inalco Meteora

Finitions
Chataignier Gold
MDI Inalco Meteora

MDI INDUCTION

Una superficie a induzione invisibile che permette di cucinare ogni tipo di alimento, unendo alte prestazioni, resistenza termica e totale continuità estetica.

EN_ An invisible-induction surface that allows you to cook any type of food, combining high performance, thermal resistance, and complete aesthetic continuity.

FR_ Une surface à induction invisible qui permet de cuisiner tout type d'aliment, alliant hautes performances, résistance thermique et continuité esthétique totale.





VITRUM

Un progetto innovativo per pensili, basi e colonne, dove la trasparenza del vetro presente anche sui fianchi crea continuità, amplifica la luce e dona al design un carattere attuale e ricercato.

EN_ An innovative concept for wall units, base units and tall units, where the transparency of the glass, also featured on the sides, creates continuity, enhances the light and gives the design a refined, contemporary character.

FR_ Un concept innovant pour les meubles hauts, bas et armoires, où la transparence du verre, présente également sur les côtés, crée une continuité, amplifie la lumière et confère au design un caractère actuel et raffiné.



Finiture

Laccato opaco Gianduia
 Laccato Plissé Opaco Gianduia
 Rovere Castoro
 Ceramica Taj Mahal

Finiture

Matt Lacquered Gianduia
 Matt Lacquered Plissé Gianduia
 Oak Veneer Castoro
 Ceramic Taj Mahal

Finiture

Laqué Mat Gianduia
 Laqué Mat Plissé Gianduia
 Chêne Castoro
 Céramique Taj Mahal



REVEGO

L'innovativo sistema Revego permette la chiusura degli spazi operativi quando non sono in uso in modo semplice e intuitivo. L'assenza di maniglia crea una gradevole pulizia di stile. Una soluzione meccanica che offre un confort di movimento molto elevato sia in apertura che in chiusura.



EN_The innovative Revego system allows the closure of operating spaces when they are not in use in a simple and intuitive way. The absence of a handle creates a pleasant, clean style. A mechanical solution that offers a very high comfort of movement both in opening and closing.

FR_Le système innovant Revego permet de fermer de manière simple et intuitive les espaces de travail lorsqu'ils ne sont pas utilisés. L'absence de poignée crée un style agréable et épuré. Une solution mécanique qui offre un très haut niveau de confort de mouvement tant à l'ouverture qu'à la fermeture.



KATE

Kate, arricchita da nuovi materiali che la rendono preziosa e ricercata, è stata studiata per agevolare la presa dell'anta: l'apertura senza maniglia consente la massima pulizia estetica e praticità d'uso.

EN_Kate, enriched with new materials that make it precious and refined, was developed to facilitate the door grabbing: the opening without handles allow the maximum clean look and ease.

FR_Kate, enrichie par des nouveaux matériaux qui la rendent plus précieuse et recherchée, a été étudiée pour faciliter la prise de la porte : l'ouverture sans poignées permet le meilleur nettoyage esthétique et la pratique d'utilisation.

Sistemi di apertura

Opening system / Système d'ouverture



Gola Systemline
Systemline Groove
Gorge Systemline

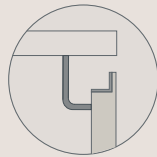

Gola Systemkappa
Systemkappa Groove
Gorge Systemkappa

FINITURE TELAIO

frame finishes / finitions du cadre



Bronzo Titanio



Champagne



Nero





Finiture
 Melaminico effetto materico Nikel
 Rovere Silvery
 Ceramica Taj Mahal

Finishes
 Material-effect Malamine Nikel
 Oak Veneer Silvery
 Ceramic Taj Mahal

Finitions
 Mèlaminé effet Structuré Nikel
 Chêne Silvery
 Céramique Taj Mahal



Finiture
 Fenix Bronzo Doha
 Noce Canaletto
 Laminato Satuario

Finishes
 Fenix Bronzo Doha
 Walnut Canaletto
 Laminato Satuario

Finitions
 Fenix Bronzo Doha
 Noyer Canaletto
 Stratifié Statuario

EXEDRA

Dotata di pratiche ante rientranti, nasconde con discrezione le aree operative, garantendo ordine, pulizia visiva e massima funzionalità.



EN_ Equipped with practical retractable doors, it discreetly conceals the work areas, ensuring order, visual cleanliness, and maximum functionality.

FR_ Dotée de portes rentrantes pratiques, elle dissimule discrètement les zones de travail, garantissant ordre, pureté visuelle et fonctionnalité maximale.





Finiture

Metallo Liquido Magnesio
 Castagno Biondo
 Laminato Rio Bravo

Finishes

Liquid Metal Magnesio
 Chestnut Biondo
 Laminato Rio Bravo

Finitions

Métal Liquide Magnesio
 Chataignier Biondo
 Stratifié Rio Bravo





KELLY

Un modello deciso e raffinato che incontra le esigenze della vita quotidiana grazie al connubio tra estetica e funzionalità. Kelly si distingue per i suoi esclusivi bordi a 30° che offrono una comoda presa per l'apertura degli elementi.

EN_A strong and refined model that meets the needs of everyday life thanks to the combination of aesthetics and functionality. Kelly stands out for its exclusive 30-degree edges that offer a comfortable grip for opening elements.

FR_Un modèle raffiné qui répond aux besoins de la vie quotidienne grâce à la combinaison de esthétique et fonctionnalité. Kelly se distingue par ses bords exclusifs à 30 degrés qui offrent une prise confortable pour ouvrir les éléments.

Sistemi di apertura

Opening system / Système d'ouverture

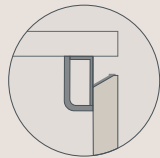

Gola Systemline
Systemline Groove
Gorge Systemline

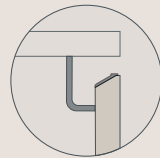

Gola Systemkappa
Systemkappa Groove
Gorge Systemkappa

FINITURE TELAIO

frame finishes / finitions du cadre



Bronzo Titanio



Champagne



Nero



Laccato opaco
matt lacquered /
laqué mat



Metallo Satinato
satin metal /
métal satiné



**Finiture**

Metallo Liquido Silicio
Noce Canaletto
Dekton Reverie

Finishes

Liquid Metal Silicio
Walnut Canaletto
Dekton Reverie

Finitions

Métal Liquide Silicio
Noyer Canaletto
Dekton Reverie

**EXEDRA**

La perfezione estetica non compromette la funzionalità: dietro le ante delle colonne, il meccanismo rientrante rivela con discrezione gli elettrodomestici, mantenendo ordine e continuità visiva.

EN_ Perfect aesthetics never compromise functionality: behind the tall-unit doors, the retractable mechanism discreetly reveals the appliances, preserving order and visual continuity.

FR_ Une esthétique parfaite ne sacrifie jamais la fonctionnalité : derrière les portes des colonnes, le mécanisme rentrant dévoile discrètement les appareils, préservant l'ordre et la continuité visuelle.



Finiture

Laccato opaco Corda
Rovere Castoro
Marmo Emperador Light

Finishes

Matt Lacquered Corda
Oak Veneer Castoro
Marble Emperador Light

Finitions

Laqué Mat Corda
Chêne Castoro
Marbre Emperador Light



TERMINALI ARROTONDATI

Linee fluide e terminali arrotondati ridisegnano lo spazio cucina con eleganza. Funzionalità e bellezza si uniscono in un design armonioso, fatto di materiali autentici e atmosfere accoglienti.

EN_Fluid lines and rounded edges redefine the kitchen space with elegance. Functionality and beauty come together in a harmonious design, made of authentic materials and inviting atmospheres.

FR_Des lignes fluides et des extrémités arrondies redessinent avec élégance l'espace cuisine. Fonctionnalité et beauté s'unissent dans un design harmonieux, fait de matériaux authentiques et d'atmosphères accueillantes.

ISABEL

Il modello Isabel nasce dall'esigenza di creare una gola integrata nell'anta, una soluzione originale che unisce praticità ed estetica. In questo modello tecnologia e grafismo si articolano in perfetta sinergia con i materiali che la caratterizzano.

EN_Kate, enriched with new materials that make it precious and refined, was developed to facilitate the door grabbing: the opening without handles allow the maximum clean look and ease.

FR_Kate, enrichie par des nouveaux matériaux qui la rendent plus précieuse et recherchée, a été étudiée pour faciliter la prise de la porte : l'ouverture sans poignées permet le meilleur nettoyage esthétique et la pratique d'utilisation.

Sistemi di apertura

Opening system / Système d'ouverture

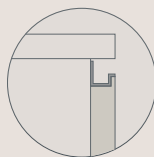

Profilo Maniglia Isabel
Isabel Handle Profile
Profil de la Poignée Isabel

FINITURE TELAIO

frame finishes / finitions du cadre



Bronzo Titanio



Champagne





Finiture
 Melaminico Quercia Malto
 Dekton Nebbia

Finishes
 Melamine Quercia Malto
 Dekton Nebbia

Finitions
 Mèlaminé Quercia Malto
 Dekton Nebbia





**Finiture**

Laccato Opaco Cashmere
 Rovere Castoro
 MDI Inalco Meteora

Finishes

Matt Lacquered Cashmere
 Oak Veneer Castoro
 MDI Inalco Meteora

Finitions

Laqué Mat Cashmere
 Chêne Castoro
 MDI Inalco Meteora

**SNACK AIR**

Convivialità allargata e spazio recuperato con lo snack AIR, dove tramite dei supporti invisibili porta tutto allo stesso piano.

EN_Expanded conviviality and recovered space with AIR snack, where invisible supports bring everything to the same level.

FR_Convivialité élargie et espace récupéré avec le snack AIR, où des supports invisibles mettent tout au même niveau.

THAI

Vano aperto che permette l'inserimento di forni, cantinette e crea un pratico piano di lavoro.



EN_ Open storage unit that allows the insertion of ovens, wine racks, and creates a handy worktop.

FR_ Compartiment ouvert qui permet d'insérer des fours, des caves à vin et de créer un plan de travail pratique.



ALEXIA

Alexia è una cucina che reinterpreta un classico senza tempo: una maniglia integrata come segno distintivo, una presa pratica e semplice, un pensiero progettuale legato ad uno stile di carattere tradizionale.

EN_Alexia is a kitchen model that reinterprets an ageless classic: an integrated handle as a distinctive sign, a practical and easy grabbing, a design thought connected with a traditional style.

FR_Alexia est une cuisine qui réinterprète un classique intemporel: une poignée insérée comme caractéristique, une prise pratique et simple, une pensée de conception liée à un style de caractère traditionnel.

Sistemi di apertura

Opening system / Système d'ouverture

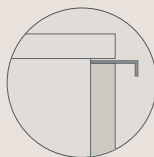

Profilo Maniglia Alexia
Alexia Handle Profile
Profil de la Poignée Alexia

FINITURE TELAIO

frame finishes / finitions du cadre



Bronzo Titanio



Champagne





Finiture

Melaminico Rasato Orzo
Rovere Silvery
Porfido Marrone Fiammato

Finishes

Melamine Rasato Orzo
Oak Veneer Silvery
Porfido Marrone Fiammato

Finitions

Mélaminé Camelia
Chêne Silvery
Porfido Marrone Fiammato



STORAGE

Corner tall unit closet / Colonne d'angle

Colonna che consente di sfruttare in tutta la sua ampiezza una zona angolare della cucina. A differenza delle colonne ad angolo tradizionali, questa soluzione permette di entrare fisicamente nella colonna, offrendo la possibilità di essere allestita internamente e di inserire alcuni elettrodomestici da libera installazione.



EN_ Tall unit that allows you to take advantage of a corner area of the kitchen in all its amplitude. Unlike traditional corner tall units, this solution allows you to physically enter the tall unit, offering the possibility of equipping it internally and inserting some freestanding appliances.

FR_Colonne permettant d'utiliser pleinement un coin de la cuisine. Contrairement aux colonnes d'angle traditionnelles, cette solution permet d'entrer physiquement dans la colonne, offrant ainsi la possibilité d'être aménagée à l'intérieur et d'insérer certains appareils électroménagers autoportants.

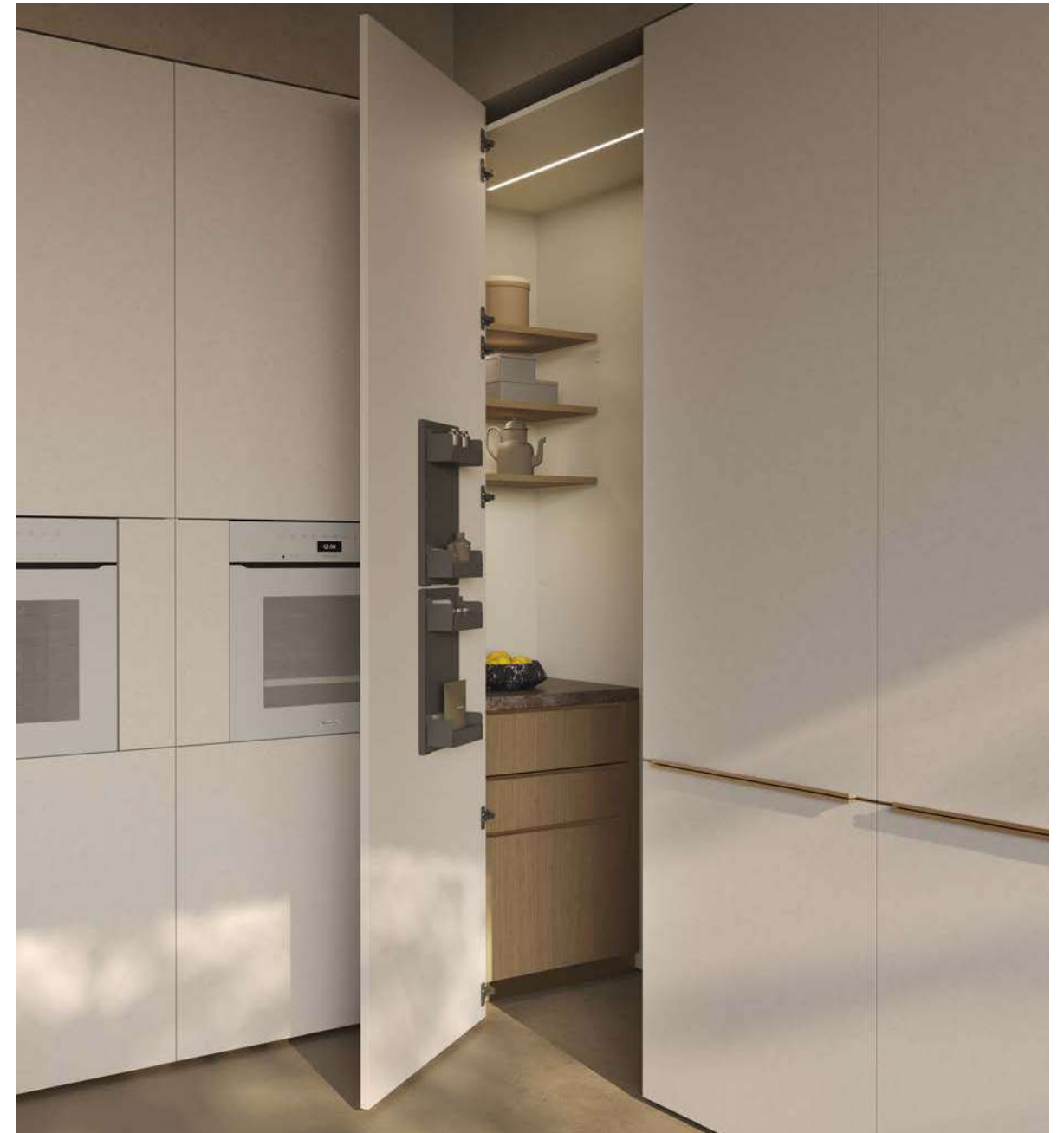

K105

K105 Collection nasce dalla cura dei dettagli, dalla ricerca nei materiali e da una visione autenticamente italiana. Una collezione versatile e funzionale, pensata per offrire massima libertà compositiva e interpretare i trend contemporanei.

EN_K105 Collection is born from meticulous attention to detail, thoughtful material research, and an authentically Italian vision. A versatile, functional collection designed to offer maximum compositional freedom and to interpret today's contemporary living trends.

FR_K105 Collection naît d'une attention minutieuse aux détails, d'une recherche soignée des matériaux et d'une vision authentiquement italienne. Une collection polyvalente et fonctionnelle, conçue pour offrir une liberté de composition maximale et interpréter les tendances contemporaines.

Sistemi di apertura

Opening system / Système d'ouverture

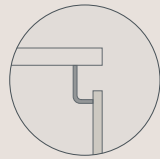

Gola Systemkappa
Systemkappa Groove
Gorge Systemkappa

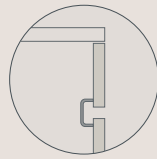

Gola intermedia
Middle Groove
Gorge intermédiaire

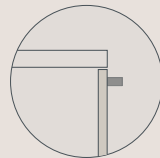

Maniglia
Handle
Poignée

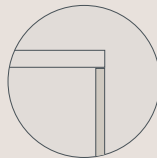

Push-pull
Push-pull handle
Push-pull





Finiture

Laccato Opaco Camelia
 Rovere Grano
 Rovere Grano Plissé
 Laminam Diamond Cream

Finishes

Matt Lacquered Camelia
 Oak Veneer Grano
 Plissé Oak Veneer Grano
 Laminam Diamond Cream

Finitions

Laqué Mat Camelia
 Chêne Grano
 Chêne Plissé Grano
 Laminam Diamond Cream



TETRIX

Utile ed innovativo canale attrezzato.

Un'idea elegante e pratica per personalizzare il piano lavoro.



EN_ Tetrrix, useful and innovative equipped canal. An elegant and practical idea to customize the worktop.

FR_Le canal équipé Tetrrix, utile et innovant. Une idée élégante et pratique pour personnaliser le plan de travail.



Finiture

Melaminico Rasato Orzo
 Melaminico Quercia Malto
 Dekton Reverie

Finishes

Melamine Rasato Orzo
 Melamine Quercia Malto
 Dekton Reverie

Finitions

Mélaminé Camelia
 Mélaminé Quercia Malto
 Dekton Reverie



GATEWAY

La porta passante Gateway rappresenta un elemento di design funzionale ideale per creare una continuità fluida tra due ambienti distinti. Progettata per unire senza separare, offre una transizione naturale, valorizzando e ampliando lo spazio.

EN_The Gateway pass-through door represents a functional design element ideal for creating fluid continuity between two distinct environments. Designed to enhance and join the spaces, expanding them naturally.

FR_La porte de passage Gateway représente un élément de design fonctionnel idéal pour créer une continuité fluide entre deux environnements distincts. Conçu pour valoriser et joindre les espaces, les agrandissent naturellement.





Finiture

Laccato Opaco Camelia
 Rovere Castoro
 MDI Inalco Gris Abujardado

Finishes

Lacquered Matt Camelia
 Oak Veneer Castoro
 MDI Inalco Gris Abujardado

Finitions

Laqué Mat Camelia
 Chêne Castoro
 MDI Inalco Gris Abujardado





CABINA WALL

Cabina wall offre uno spazio contenitivo da accessorizzare a piacimento per diventare dispensa, spazio dove riporre piccoli elettrodomestici, zona lavanderia, oppure ripostiglio.

EN_Wall unit that offers a storage space that can be accessorised as desired to become a pantry, a space for storing small appliances, a laundry area,

FR_Cabine murale, il offre un espace de rangement qui peut être accessorisé à volonté pour devenir un garde-manger, un espace de rangement pour le petit électroménager, un espace buanderie ou une buanderie.



ELECTA

Libreria caratterizzato dalla libertà di scelta in altezza e di posizione degli elementi, con la possibilità di creare molteplici configurazioni libere oppure a parete.



EN_A bookcase system characterised by the freedom of choice in height and position of the elements, with the possibility of creating multiple free or wall configurations.

FR_Un système de bibliothèque caractérisé par la liberté de choix de la hauteur et de la position des éléments, avec la possibilité de créer de multiples configurations autoportantes ou murales.

K-CONCEPT

Pannello luminoso che, utilizzato come schienale, consente di illuminare in modo confortevole il piano di lavoro. La linea di accessori dedicata, comprensiva di mensole, ganci, porta rotoli e prese elettriche, consente di organizzare al meglio lo spazio di lavoro.



EN_ Light panel that, used as backing, allows you to comfortably illuminate the worktop. The dedicated line of accessories, including shelves, hooks, paper roll holders and electrical outlets, allows you to better organise your work space.

FR_Panneau lumineux qui, lorsqu'il est utilisé comme dossier, permet d'éclairer confortablement le plan de travail. La gamme d'accessoires dédiée, comprenant des étagères, des crochets, des porte-rouleaux et des prises électriques, vous permet d'organiser votre espace de travail de la meilleure façon possible.

Frame 1.5 / Frame 5.0

Massima libertà, massima coerenza.

Ritmo colore e natura si incontrano nelle collezioni cucina Frame. Spazi che si adattano al vivere contemporaneo, mantenendo intatta l'armonia del design italiano e un gusto autenticamente internazionale.

EN_ Frame. Maximum freedom, maximum consistency. Colour, rhythm and nature come together in the Frame kitchen collections. Spaces that adapt to contemporary living while preserving the harmony of Italian design and an authentically international appeal.

FR_ Frame. Liberté maximale, cohérence maximale. Couleur, rythme et nature se rencontrent dans les collections de cuisines Frame. Des espaces qui s'adaptent à la vie contemporaine, tout en conservant l'harmonie du design italien et une esthétique authentiquement internationale.

FRAME 1.5

Si presenta come una celebrazione dell'equilibrio formale, dove ogni dettaglio parla di ordine e precisione. Una cornice perimetrale sottile, di appena 14 mm, contorna con discrezione ma decisione l'intera struttura, conferendo un senso di rigore e armonia visiva.

EN_**FRAME 1.5** is a celebration of formal balance, where every detail speaks of order and precision. A thin perimeter frame, just 14 mm wide, discreetly yet decisively outlines the entire structure, conveying a sense of rigor and visual harmony.

FR_**FRAME 1.5** se présente comme une célébration de l'équilibre formel, où chaque détail évoque l'ordre et la précision. Un cadre périphérique fin, d'à peine 14 mm, entoure avec discrétion mais détermination l'ensemble de la structure, conférant un sentiment de rigueur et d'harmonie visuelle.



Finiture

Finishes/Finitions

Essenze: 5 essenze Rovere,
1 essenza Termocotto e 3 essenze
Castagno

EN_ Veneers: 5 Oak veneers, 1 Hot
treated oak veneers and 3 Chestnut
veneers

FR_ Placage Bois: 5 placage bois Chêne,
1 placage bois Chené Termocotto e 3
placage bois Chataignier

Colore: 25 laccati opachi
EN_ Color finishes: 25 mat lacquered
FR_ Color finitions: 25 laqué mat

Sistemi di apertura

Système d'ouverture/Opening system

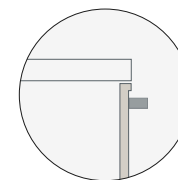

Maniglia
Handle
Poignée

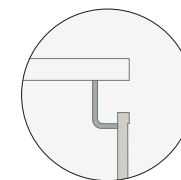

Gola Systemkappa
Systemkappa Groove
Gorge Systemkappa

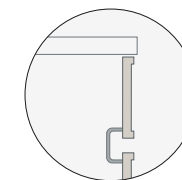

Gola intermedia
Middle Groove
Gorge intermédiaire

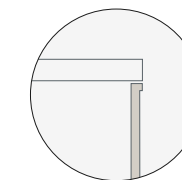

Push-pull
Push-pull handle
Push-pull



Finiture
Laccato Opaco Camelia
Laccato Opaco Anfora
Dekton Nebbia

Finishes:
Matt lacquered Camelia
Matt lacquered Anfora
Dekton Nebbia

Finitions:
Laqué mat Camelia
Laqué mat Anfora
Dekton Nebbia







Finiture:
Laccato opaco Ghiia
Rovere Ghianda
Dekton Reverie

Finishes:
Matt lacquered Ghiia
Oak Ghianda
Dekton Reverie

Finitions:
Laqué mat Ghiia
Chêne Ghianda
Dekton Reverie

FRAME 1.5

Una calda atmosfera di luci soffuse e ulivi accende la cucina con un tocco mediterraneo di eleganza e serenità.

EN_ A warm atmosphere of soft lighting and olive trees illuminates the kitchen with a Mediterranean touch of elegance and serenity.

FR_ Une atmosphère chaleureuse créée par des lumières tamisées et des oliviers illumine la cuisine d'une touche méditerranéenne d'élégance et de sérénité.



FRAME 5.0

Esprime una visione solida e attuale: un'anta con telaio da 50 mm che conferisce alla cucina un carattere deciso, un perfetto equilibrio geometrico e uno stile contemporaneo.

EN_ FRAME 5.0 embodies a solid, modern vision: a 50 mm frame door that gives the kitchen a bold character, perfect geometric balance, and a contemporary style.

FR_ FRAME 5.0 exprime une vision solide et actuelle: une porte avec un cadre de 50 mm qui confère à la cuisine un caractère affirmé, un équilibre géométrique parfait et un style contemporain.



Finiture

Finishes/Finitions

Essenze: 5 essenze Rovere, 3 essenze Castagno
 EN_ Veneers: 5 Oak veneers, 3 Chestnut veneers
 FR_ Placage Bois: 5 placage bois Chêne, 3 placage bois Chataignier

Colore: 25 laccati opachi
 EN_ Color finishes: 25 mat lacquered
 FR_ Color finitions: 25 laqué mat

Sistemi di apertura

Système d'ouverture/Opening system

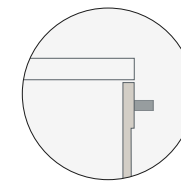

Maniglia
Handle
Poignée

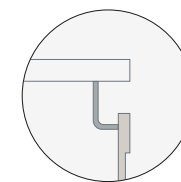

Gola Systemkappa
Systemkappa Groove
Gorge Systemkappa

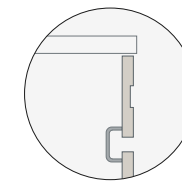

Gola intermedia
Middle Groove
Gorge intermédiaire

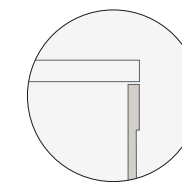

Push-pull
Push-pull handle
Push-pull

FW05

Le vetrine con cornici contemporanee disegnano geometrie leggere, combinando trasparenza e linee pulite in un'eleganza che fonde passato e presente.

EN_FW05, display cabinets with contemporary frames create light geometric shapes, combining transparency and clean lines in an elegant style that blends past and present.

FR_FW05, les vitrines aux cadres contemporains dessinent des géométries légères, alliant transparence et lignes épurées dans une élégance qui fusionne passé et présent.



Vetro cannettato
satinato

EN_ Fluted etched glass
FR_Verre acide rainuré

Vetro bronzato
trasparente

EN_Bronzed transparent glass
FR_Verre bronzé transparent

Vetro trasparente

EN_Transparent glass
FR_Verre transparent



Finiture:
Laccato opaco Camelia
Larice Arctic
Quarzite Cosmopolitan

Finishes:
Matt lacquered Camelia
Larch Arctic
Quarzite Cosmopolitan

Finitions:
Laqué mat Camelia
Mélèze Arctic
Quarzite Cosmopolitan





Libreria COTTAGE

Cottage, la libreria dalle proporzioni leggere e raffinate, progettata per integrarsi con naturalezza tra le basi cucina e dare vita a un equilibrio armonioso tra contenimento, estetica e leggerezza formale.

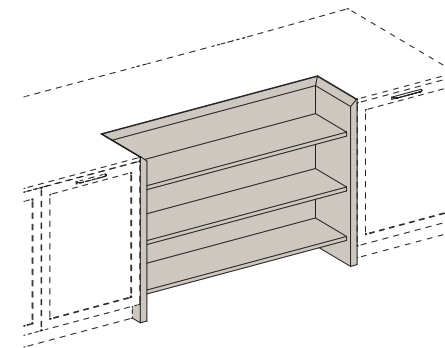

EN_Cottage, a bookcase with light and elegant proportions, conceived to integrate seamlessly between the kitchen bases, achieving a harmonious balance of storage, aesthetics, and formal lightness.

FR_Cottage, la bibliothèque aux proportions légères et raffinées, conçue pour s'intégrer naturellement entre les éléments bas de la cuisine et créer un équilibre harmonieux entre rangement, esthétique et légèreté formelle.



Finiture:
Rovere Ghianda
Rovere Ghianda plissé
Ceramica Blanco Arenado

Finishes:
Oak Ghianda
Oak Ghianda Plissé
Ceramica Blanco Arenado

Finitions:
Chêne Ghianda
Chêne Ghianda Plissé
Ceramica Blanco Arenado

FRAME 5.0

Il fianco curvo e le ante in rovere plissé conferiscono alla composizione un autentico senso di charme.

EN_The curved side panel and the pleated oak doors give the composition an authentic sense of charm.

FR_Le flanc courbe et les portes en chêne plissé confèrent à la composition un authentique sens du charme.





Finiture:
 Laccato opaco Gianduia
 Plissé Gianduia
 Quarzite Taj

Finishes:
 Matt Lacquered Gianduia
 Pleated Gianduia
 Quarzite Taj

Finitions:
 Laqué mat Gianduia
 Plissé Gianduia
 Quarzite Taj





REVEGO

L'innovativo sistema Revego permette la chiusura degli spazi operativi quando non sono in uso in modo semplice e intuitivo. L'assenza di maniglia crea una gradevole pulizia di stile. Una soluzione meccanica che offre un confort di movimento molto elevato sia in apertura che in chiusura.



EN_The innovative Revego system allows the closure of operating spaces when they are not in use in a simple and intuitive way. The absence of a handle creates a pleasant, clean style. A mechanical solution that offers a very high comfort of movement both in opening and closing.

FR_Le système innovant Revego permet de fermer de manière simple et intuitive les espaces de travail lorsqu'ils ne sont pas utilisés. L'absence de poignée crée un style agréable et épuré. Une solution mécanique qui offre un très haut niveau de confort de mouvement tant à l'ouverture qu'à la fermeture.



Finiture:

Laccato opaco Cashmere
 Laccato opaco Alloro
 Rovere Castoro
 Ceramica Calacatta Imperiale

Finishes:

Matt lacquered Cashmere
 Matt lacquered Alloro
 Oak Castoro
 Ceramica Calacatta Imperiale

Finitions:

Laqué mat Cashmere
 Laqué mat Alloro
 Chêne Castoro
 Ceramica Calacatta Imperiale

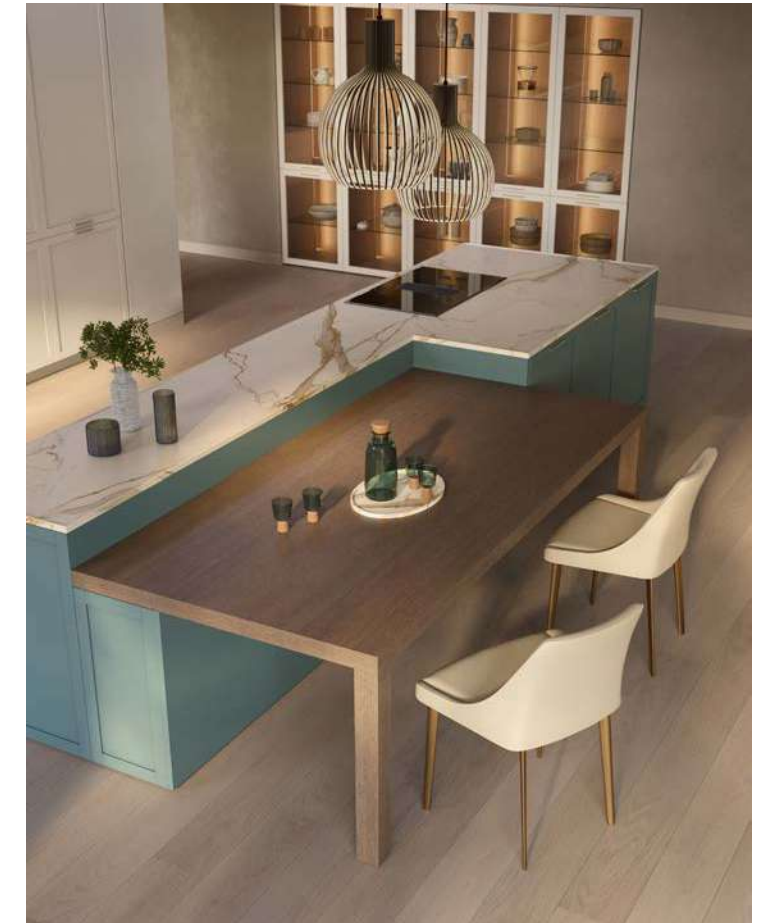





Finiture:

Laccato opaco Cashmere
 Laccato opaco Alloro
 Rovere Castoro
 Ceramica Calacatta Imperiale

Finishes:

Matt lacquered Cashmere
 Matt lacquered Alloro
 Oak Castoro
 Ceramica Calacatta Imperiale

Finitions:

Laqué mat Cashmere
 Laqué mat Alloro
 Chêne Castoro
 Ceramica Calacatta Imperiale





ELEMENTI SPECIALI

Special Elements / Éléments Spéciaux

	Pag
Revego	142
Storage	144
Exedra	146
Wall	148
Thai	150
Gateway	151
Va e Vieni	152
Vitrum	156
Electa	158

REVEGO

L'innovativo sistema Revego permette la chiusura degli spazi operativi quando non sono in uso in modo semplice e intuitivo.

EN_ The innovative Revego system allows the closure of operating spaces when they are not in use in a simple and intuitive way.

FR_ Le système innovant Revego permet de fermer de manière simple et intuitive les espaces de travail lorsqu'ils ne sont pas utilisés.



Altezze/Heights/Hauteurs

- H 236 cm
- H 238 cm
- H 240 cm
- H 254 cm
- H 256 cm
- H 258 cm

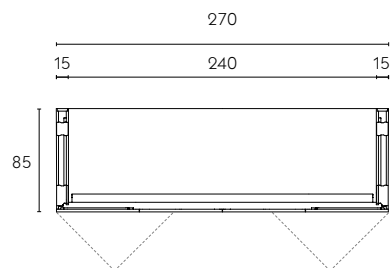

Esempi/Examples

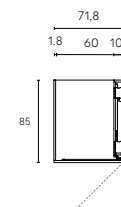
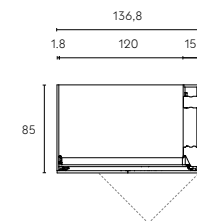
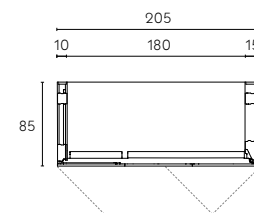
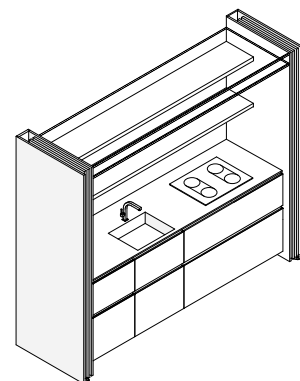
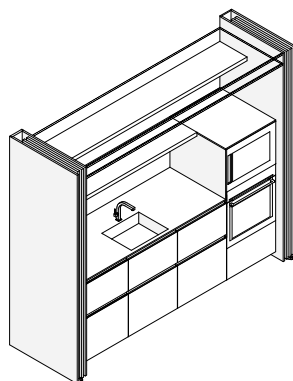

Esempi/Examples

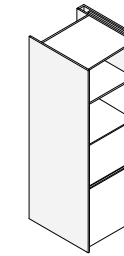
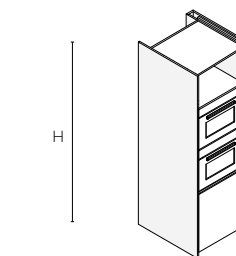
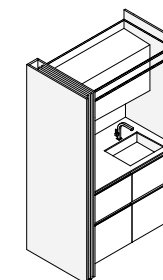
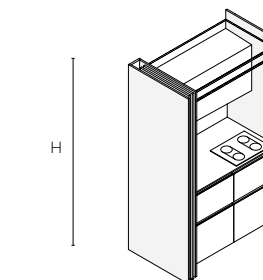
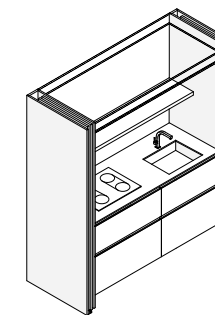
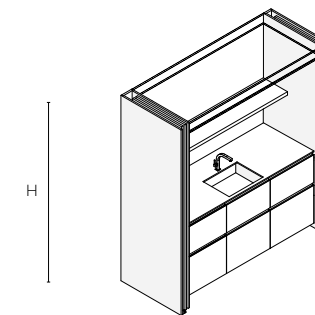

STORAGE

Corner tall unit closet / Colonne d'angle

A differenza delle colonne ad angolo tradizionali, questa soluzione permette di entrare fisicamente nella colonna, offrendo la possibilità di essere allestita internamente e di inserire alcuni elettrodomestici da libera installazione.

EN_Unlike traditional corner tall units, this solution allows you to physically enter the tall unit, offering the possibility of equipping it internally and inserting some freestanding appliances.

FR_Contrairement aux colonnes d'angle traditionnelles, cette solution permet d'entrer physiquement dans la colonne, offrant ainsi la possibilité d'être aménagée à l'intérieur et d'insérer certains appareils électroménagers autoportants.

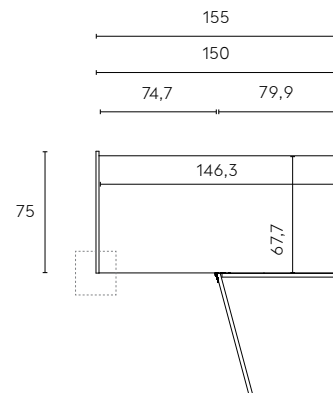
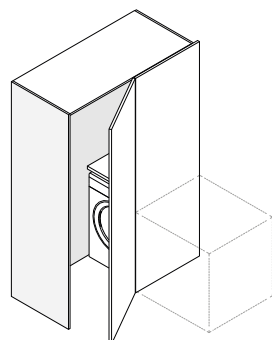
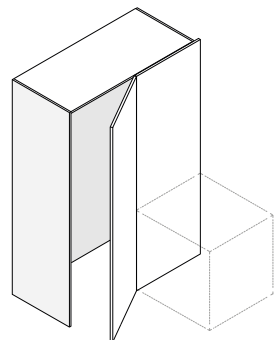

Gola
Groove
Gorge

Maniglia
Handle
Poignée

Push-pull
Push-pull
Push-pull

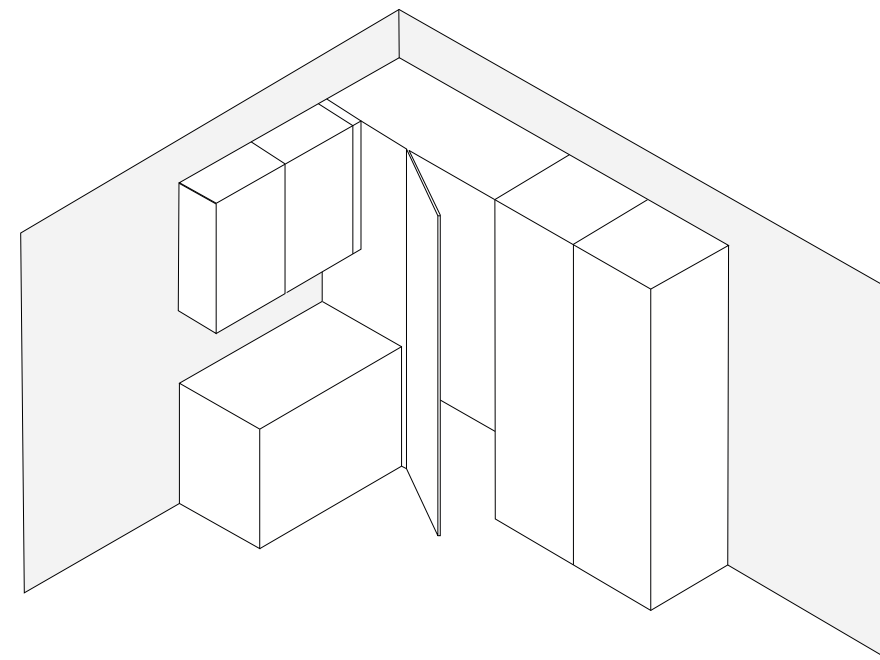
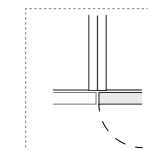
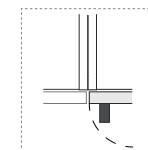
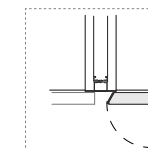

EXEDRA

Sistema per ante a scomparsa, caratterizzato da un movimento assistito e ammortizzato sia in apertura sia in rientro. Adatto per numerose applicazioni che permettono di sfruttare lo spazio per svariate necessità.



EN_System for concealed doors, featuring assisted and cushioned movement both when opening and closing. Suitable for numerous applications that allow you to make the most of the space for a variety of needs.

FR_Système pour portes escamotables, caractérisé par un mouvement assisté et amorti tant à l'ouverture qu'à la fermeture. Convient à de nombreuses applications permettant d'exploiter l'espace pour divers besoins.

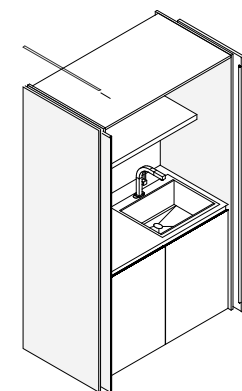

138,4

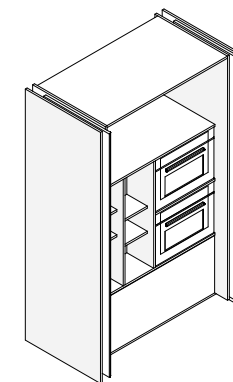
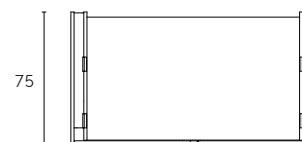

138,4

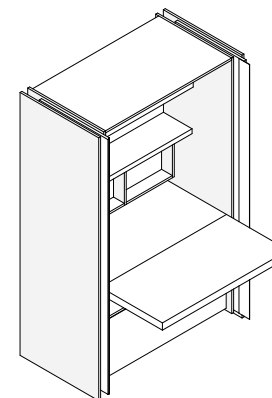
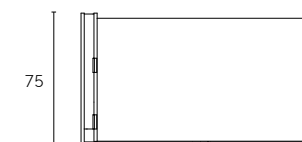

138,4

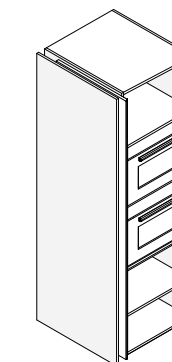
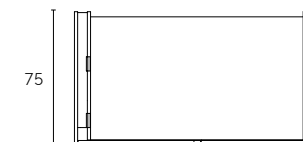

71,1

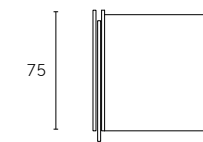

WALL

Cabina wall, offre uno spazio contenitivo da accessoriare a piacimento per diventare dispensa, spazio dove riporre piccoli elettrodomestici, zona lavanderia, oppure ripostiglio.

EN_Wall cabinet, offering storage space that can be accessorised as desired to become a pantry, a space for storing small appliances, a laundry area or a storage room.

FR_La cabine murale offre un espace de rangement à accessoriser à votre guise pour devenir un garde-manger, un espace où ranger de petits appareils électroménagers, une buanderie ou un débarras.



Zoccolo / Plinth / Socle H 6
H 205-217-229-235-241-253-265

Zoccolo / Plinth / Socle H 8
H 207-219-231-237-243-255-267

Zoccolo / Plinth / Socle H 10
H 209-221-233-239-245-257-269

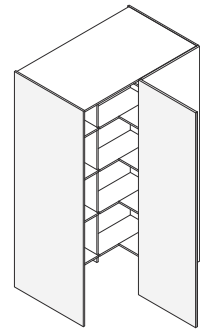

DX -SX

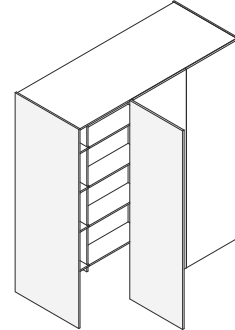
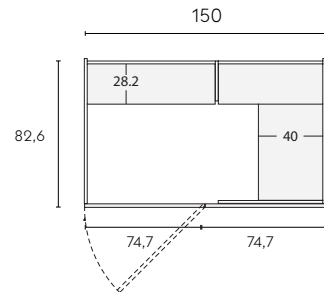

DX -SX

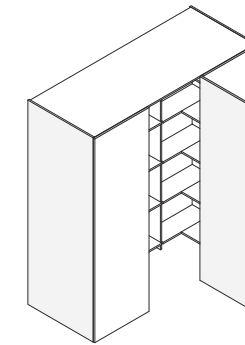
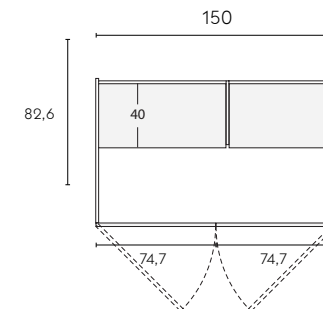
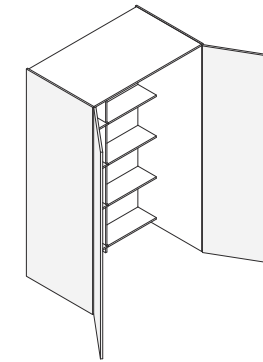
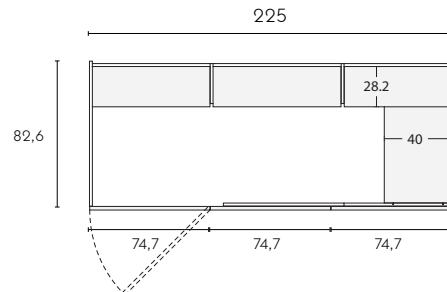

DX -SX

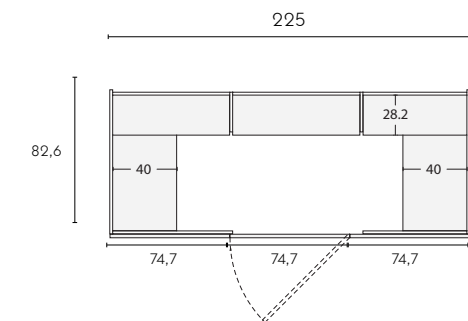

THAI

Vano aperto che permette l'inserimento di forni, cantinette e crea un pratico piano di lavoro.

EN_Open compartment that allows for the insertion of ovens and wine coolers and creates a practical work surface.

FR_Compartment ouvert permettant d'y insérer des fours, des caves à vin et créant un plan de travail pratique.

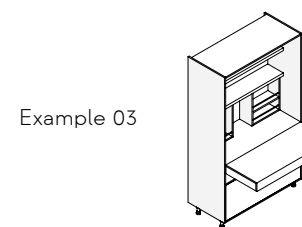
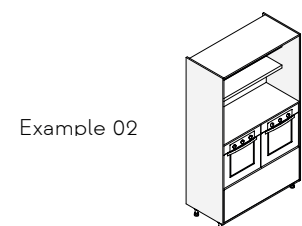
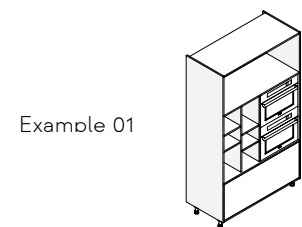
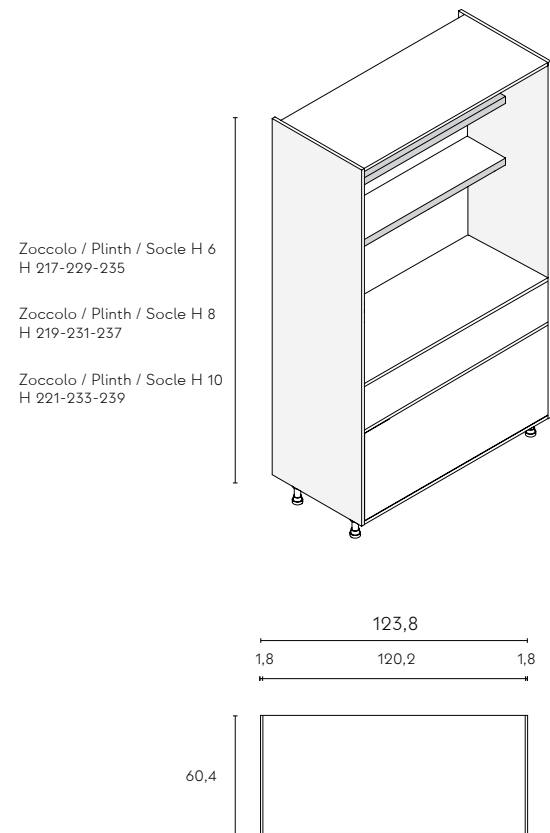

GATEWAY

La porta passante Gateway rappresenta un elemento di design funzionale ideale per creare una continuità fluida tra due ambienti distinti. Progettata per unire senza separare, offre una transizione naturale, valorizzando e ampliando lo spazio.

EN_The Gateway pass-through door represents a functional design element ideal for creating fluid continuity between two distinct environments. Designed to enhance and join the spaces, expanding them naturally.

FR_La porte de passage Gateway représente un élément de design fonctionnel idéal pour créer une continuité fluide entre deux environnements distincts. Conçu pour valoriser et joindre les espaces, les agrandissent naturellement.

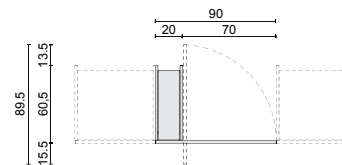
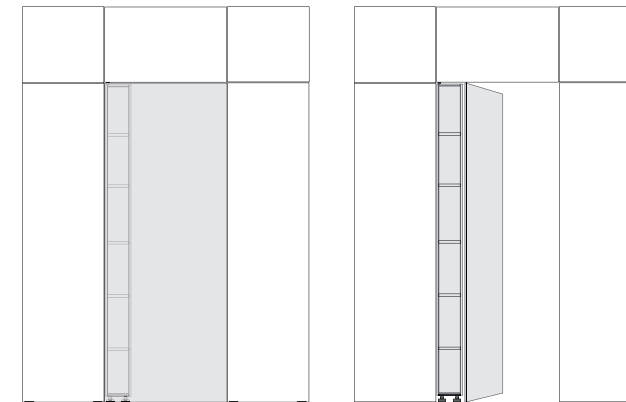

Zoccolo / Plinth / Socle H 6
H 217-229-235

Zoccolo / Plinth / Socle H 8
H 219-231-237

Zoccolo / Plinth / Socle H 10
H 221-233-239

VA E VIENI

Grazie a due apposite staffe, permette di creare sistemi di chiusura che sfruttano i pannelli frontali. Una soluzione versatile e funzionale.

EN_ Vai e Vieni, thanks to two dedicated brackets, allows the creation of closure systems that make use of the front panels. A versatile and functional solution.

FR_Vai e Vieni, grâce à deux supports dédiés, permet de créer des systèmes de fermeture utilisant les panneaux frontaux. Une solution polyvalente et fonctionnelle.

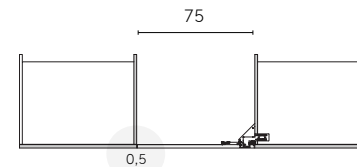

Luce tra anta VA E VIENI e anta colonna adiacente.
EN_ gap between "VA E VIENI" and door of adjacent cupboard / tall unit.
FR_ espace entre "VA E VIENI" et porte de l'armoire/colonne adjacente.

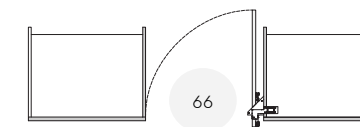

Larghezza utilizzabile escluso lo spessore della maniglia, se installata.
EN_ Usable passage width not including the thickness the handle if fitted.
FR_ Largeur utilisable à l'exclusion de l'épaisseur de la poignée, si installée.

Zoccolo H 6
H 145-205-217-229-235-241

Zoccolo H 8
H 147-207-219-231-237-243

Zoccolo H 10
H 149-209-221-233-239-245

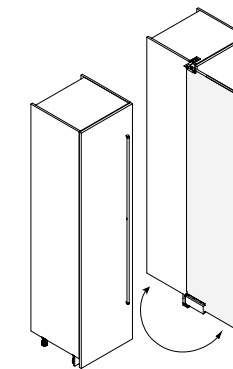
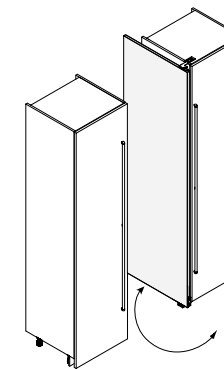
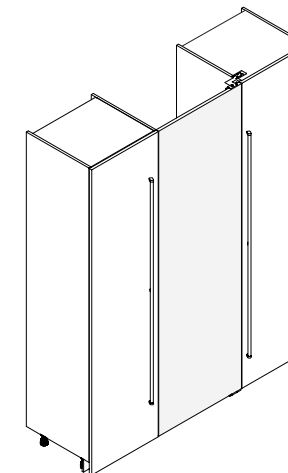

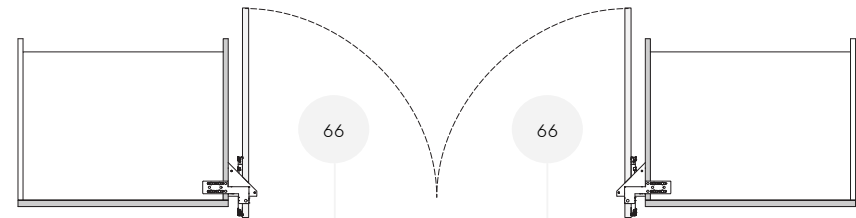
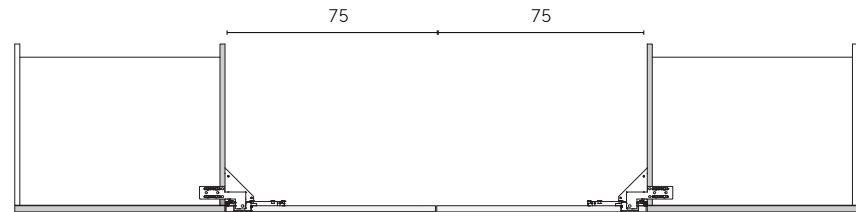

Larghezza utilizzabile escluso lo spessore della maniglia, se installata.
 EN_ Usable passage width not including the thickness the handle if fitted.
 FR_ Largeur utilisable à l'exclusion de l'épaisseur de la poignée, si installée.

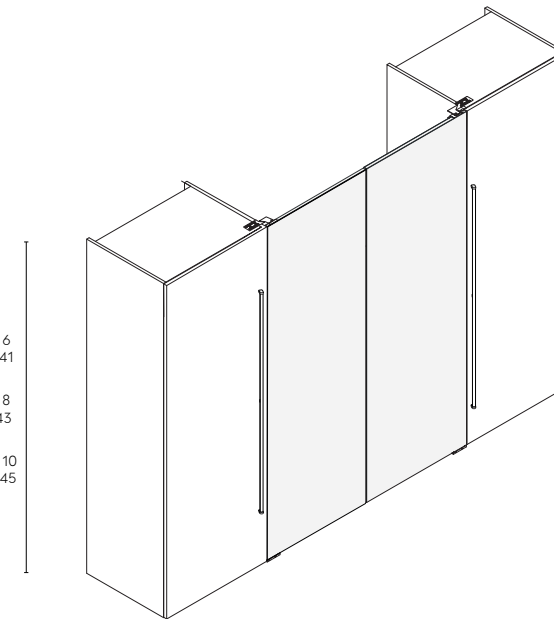

Zoccolo / Plinth / Socle H 6
 H 145-205-217-229-235-241

Zoccolo / Plinth / Socle H 8
 H 147-207-219-231-237-243

Zoccolo / Plinth / Socle H 10
 H 149-209-221-233-239-245

VA E VIENI versione a due ante

trasforma l'anta di una colonna in una porta passante bidirezionale, integrata con continuità nella zona colonne della cucina.

EN_ VA E VIENI double-door version

transforms a tall-unit door into a bidirectional passage door, seamlessly integrated into the kitchen column area.

FR_ VA E VIENI version à deux battants

transforme la porte d'une colonne en une porte passante bidirectionnelle, parfaitement intégrée à l'ensemble des colonnes de la cuisine.

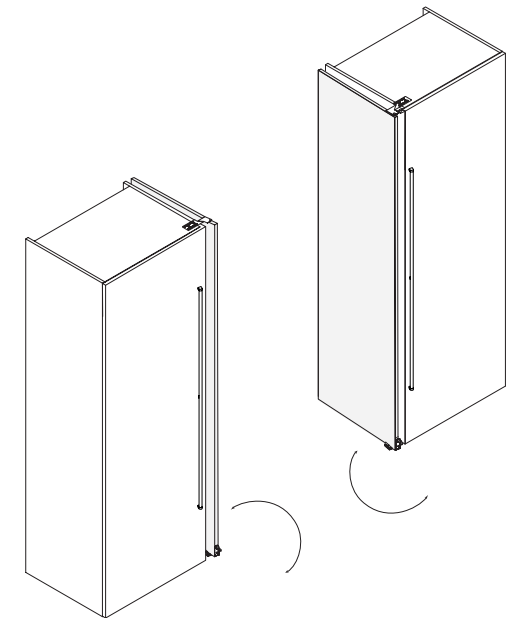

VITRUM

Un progetto innovativo per pensili, basi e colonne, dove la trasparenza del vetro presente anche sui fianchi crea continuità, amplifica la luce e dona al design un carattere attuale e ricercato.

EN_ An innovative concept for wall units, base units and tall units, where the transparency of the glass, also featured on the sides, creates continuity, enhances the light and gives the design a refined, contemporary character.

FR_ Un concept innovant pour les meubles hauts, bas et armoires, où la transparence du verre, présente également sur les côtés, crée une continuité, amplifie la lumière et confère au design un caractère actuel et raffiné.



PENSILI
Wall Units
Meubles Hauts

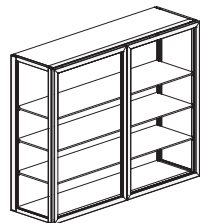

BASI
Bases
Bas

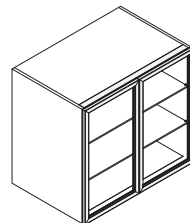

COLONNE
Tall Units
Armoires

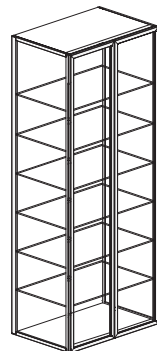

Cielo / Schiena / Fondo: materiali disponibili
Top / Back / Bottom: materials available
Ciel / Dos / Fond : matériaux disponibles

Matt and glossy lacquer / Laqué mat et brillant

Ripiano vetro: finiture
Glass shelf: finishes
étagère en verre : finitions

- Trasparente
- Fumé
- Bronzato trasparente

Fianco alluminio senza vetri di serie: finiture
Aluminum side without glass: finishes
Côté aluminium sans vitrage standard : finitions

- Nero
- Champagne

Distanza tra ripiano e fianco esterno con vetro
Distance between shelf and external side with glass
Distance entre l'étagère et le côté extérieur avec le verre

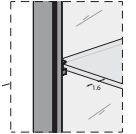

Distanza tra ripiano con fianchi adiacenti senza vetro
Distance between shelves in case of side without glass
Distance entre les étagères dans le cas de côtés sans verre

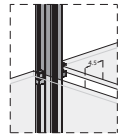

Anta T65
T65 door
Porte T65

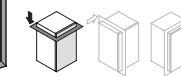

Profilo alluminio su cielo e fondo
Aluminum profile on top and bottom panels
Profil aluminium en haut et en bas

- Nero
- Champagne

ALLESTIMENTO INTERNO
INTERIOR DESIGN / AMÉNAGEMENT INTÉRIEUR

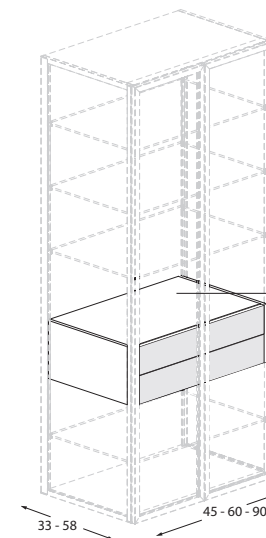

Cassettiera interna
Internal drawer unit
Meuble interne avec tiroirs

Melaminico
Melamine / Mèlamine

Laccato opaco e lucido
Matt and glossy lacquer /
Laqué mat et brillant

Impiallacciati
Veneers / Placage

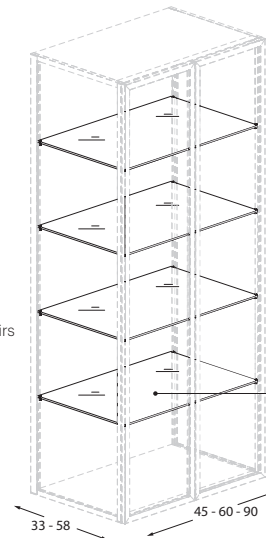

Led per fianco luminoso
Led light for side panel
Led pour côté lumineux

Ripiani vetro
Glass shelves
étagères en verre

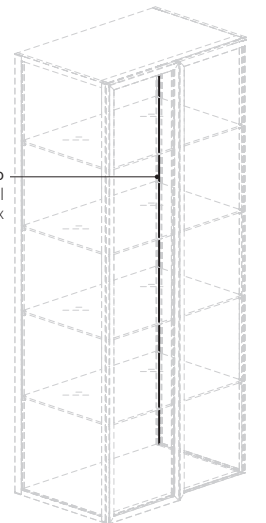

ELECTA

Libreria caratterizzato dalla libertà di scelta in altezza e di posizione degli elementi, con la possibilità di creare molteplici configurazioni libere oppure a parete.

EN_A bookcase system characterised by the freedom of choice in height and position of the elements, with the possibility of creating multiple free or wall configurations.

FR_Un système de bibliothèque caractérisé par la liberté de choix de la hauteur et de la position des éléments, avec la possibilité de créer de multiples configurations autoportantes ou murales.

DIMENSIONI LIBRERIA

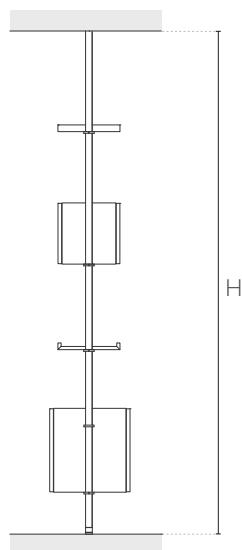

H max: 300; H min: 200

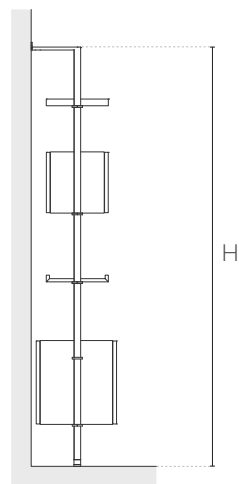

H max: 250; H min: 200



COMPONENTI MODULARI LIBRERIA ELECTA

- A - Mensola spessore 4 cm
Etagère ép. 4 cm
- B - Mensola folding- "vassoio"
Etagère en folding
- C - Contenitore con cestone
Meuble avec 1 casseroier
- D - Contenitore apertura ribalta verso il basso
Meuble avec 1 porte ouverture vers le bas
- E - Top optional spessore 12 mm
Panneau en option ép. 12 mm
- F - Contenitore apertura ribalta verso basso o verso l'alto
Meuble ouverture vers le bas ou vers le haut
- G - Contenitore con due cassetti
Meuble avec 2 tiroirs
- H - Contenitore con due cassetti e un cesto
Meuble avec 2 tiroirs et 1 casseroier

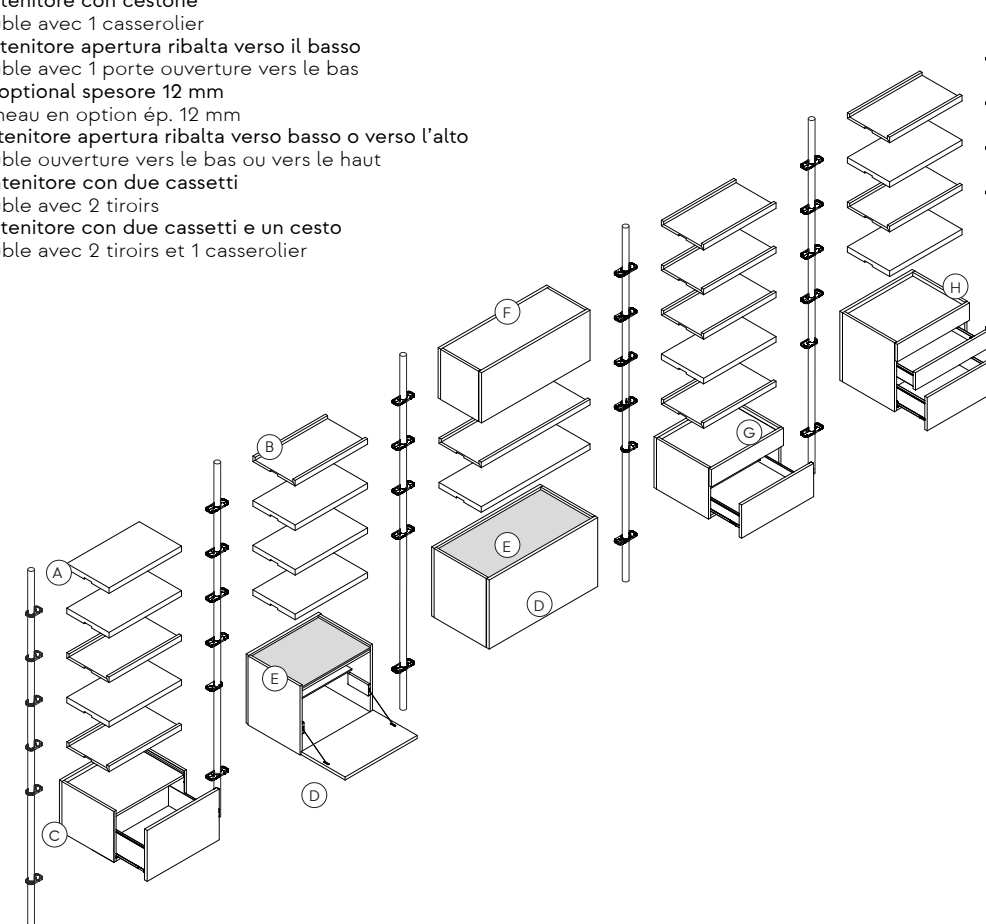

LIBRERIA ELECTA ESEMPI COMPOSITIVI

Esempi libreria electa a soffitto

H max: 300; H min: 200

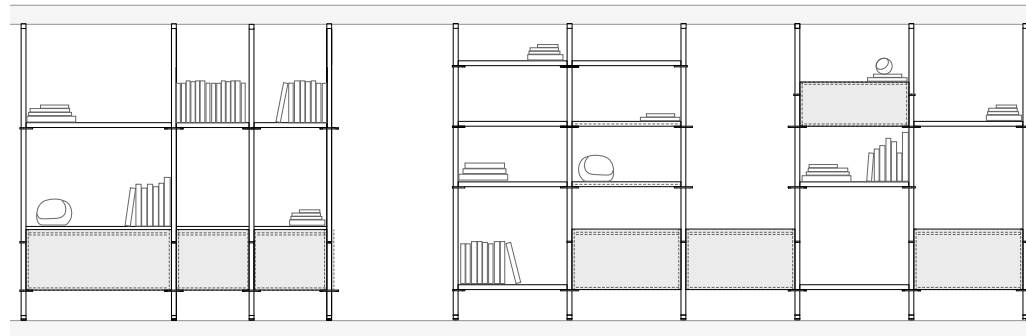
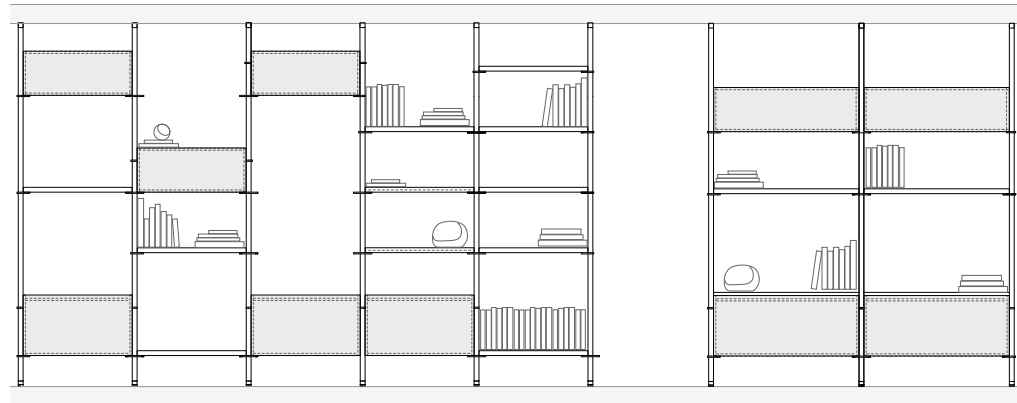

Esempi libreria electa a muro

H max: 250; H min: 200

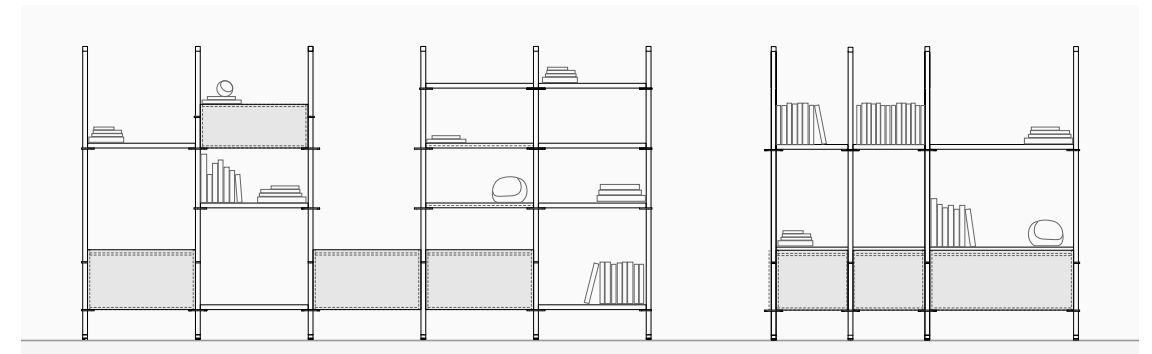
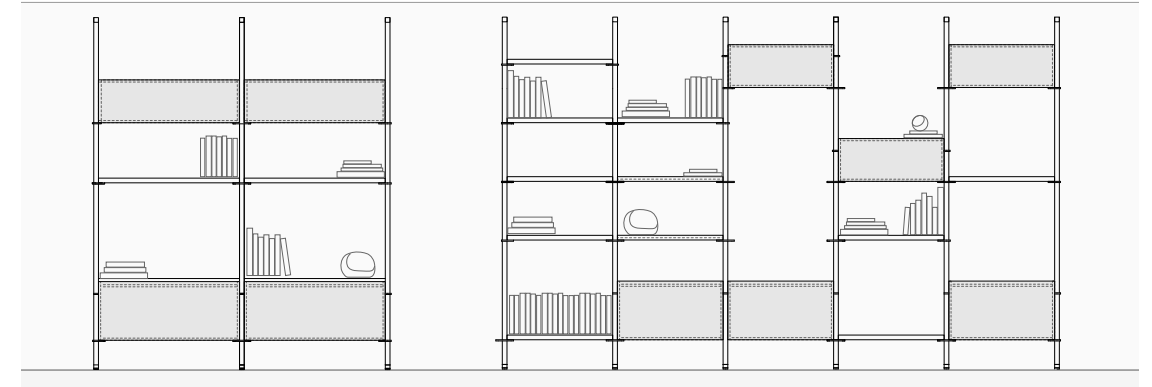

MATERIALI

Ricerchiamo e selezioniamo con grande cura materiali e texture in modo che possano soddisfare gusti e budget differenti. Si tratta di una ricerca stilistica che tiene in considerazione mode, tendenze, usi e costumi del mondo che ci circonda.

EN_We seek and pick materials and textures with great care so that they can satisfy different tastes and budgets. It is a stylistic research that takes into account fashions, trends and customs of the world around us.

FR_Nous recherchons et sélectionnons les matériaux et textures avec le plus grand soin afin qu'ils puissent satisfaire différents goûts et budgets. Il s'agit d'une recherche stylistique qui prend en compte les modes, les tendances et les coutumes du monde qui nous entoure.

METALLO VERNICIATO PAINTED METAL / MÉTAL VERNI

Sp. 12 mm



202 Brushed stone sb4 lava



208 Metal raw mr1 ferro



210 Metal raw mr4 bronzo fiammato

Disponibili per / available for / disponibles pour: T80

METALLO SATINATO SATIN METAL / MÉTAL SATINÉ

Sp. 22 mm



70A Carbonio



70B Glam



70C Dark bronze



70D Copper

Disponibili per / available for / disponibles pour: K105 - PROFILE COLLECTION - T80

METALLO LIQUIDO

LIQUID METAL / MÉTAL LIQUIDE

Sp. 22 mm



650 Oro rosa

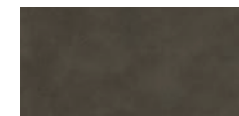

651 Zirconio

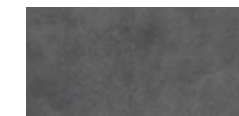

652 Silicio



653 Magnesio

Disponibili per / disponibles pour / available for: K105 - PROFILE COLLECTION

LAMINAM

COLLEZIONE IN-SIDE

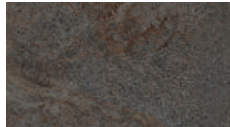

254 Porfido marrone fiammato

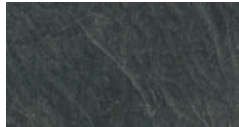

251 Pietra di Cardoso nero fiammato

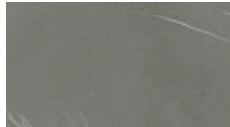

252 Pietra piacentina grigio fiammato

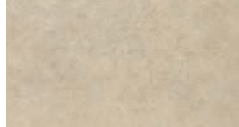

256 Terra di Matera fiammato

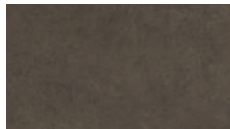

257 Terra di Pompei fiammato

Disponibili per / available for / disponibles pour: T70

COLLEZIONE I NATURALI



255 Travertino grigio venato bocciardato



253 Pietra di Savoia perla bocciardata



250 Diamond cream

Sp. 23 mm

MDi by Inalco

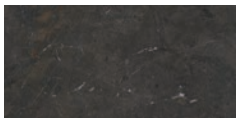

267 Umbra marron abujardado

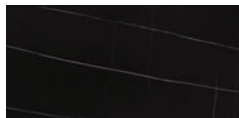

261 Azalai negro natural



266 Totem gris abujardado



264 Meteora gris abujardado



263 Jasper moka abujardado



260 Ananda blanco arenado

Disponibili per / available for / disponibles pour: T70

Sp. 22 mm

DEKTON

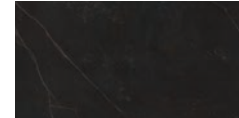

018 Kelya



003 Sirius

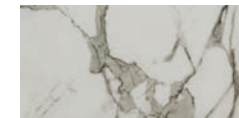

023 Aura 22

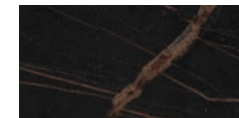

028 Laurent



033 Morpheus

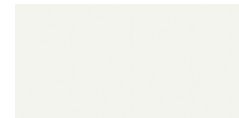

001 Zenith

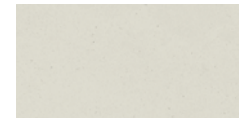

024 Aeris

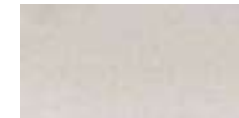

031 Nebbia



032 Somnia



034 Reverie

Disponibili per / available for / disponibles pour: T70

Sp. 22 mm

VETRI GLASS / VERRE



725 Bianco light

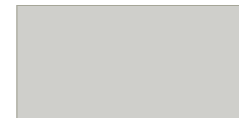

702 Sabbia

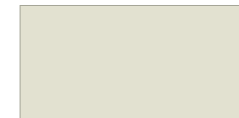

703 Corda



742 Soia



743 Camoscio



729 Roccia



710 Antracite



759 Nero assoluto



730 Caramello



748 Marsala



732 Muschio



980 Opaco e Lucido a Campione
980 Opaque and Glossy as per Sample
980 Opaque et Brillant Selon Échantillon

Disponibili per / available for / disponibles pour: T70

Sp. 22 mm

LEGNO ANTICO ANTIQUE WOOD / VIEUX BOIS



580 Rovere komi



581 Abete talco



582 Abete multicolor

Sp. 22 mm



Venatura verticale
Vertical grain
Veinure verticale

ANTA LISCIA (Sp. 22 mm) / SMOOTH DOOR / PORTE LISSE

Disponibili per / available for / disponibles pour: K105 - KATE - KELLY COLLECTION

ROVERE - ROVERE PLISSE' OAK VENEER - PLISSÉ OAK / CHÊNE - CHÊNE PLISSÉ



559 Rovere grano



560 Rovere ghianda



561 Rovere silvery

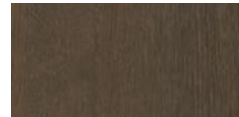

562 Rovere castoro

Sp. 23 mm



Venatura verticale
Veinure verticale
Vertical grain



563 Rovere lava

Disponibili per / available for / disponibles pour: K105 - PROFILE COLLECTION - FRAME 1.5 - FRAME 5.0 - T70 - T80

PLISSÉ Disponibili per / available for / disponibles pour: K105 - PROFILE COLLECTION

ROVERE NODATO KNOTTED OAK / CHÊNE NOUE



384 Nodato grano



385 Nodato ghianda



386 Nodato silvery



387 Nodato castoro

Sp. 23 mm



Venatura verticale
Veinure verticale
Vertical grain



388 Nodato lava

Disponibili per / available for / disponibles pour: K105 - PROFILE COLLECTION

TERMOCOTTO HEAT-TREATED OAK / CHÊNE TERMOCOTTO

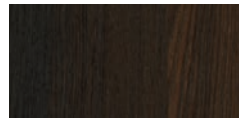

360 Rovere termocotto

Sp. 23 mm



Venatura verticale
Veinure verticale
Vertical grain

Disponibili per / available for / disponibles pour: K105 - PROFILE COLLECTION - FRAME 1.5 - T70 - T80

CASTAGNO CHESTNUT / CHÂTAIGNIER

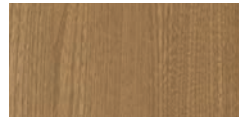

570 Castagno biondo



571 Castagno fumo



572 Castagno gold

Sp. 23 mm



Venatura verticale
Veinure verticale
Vertical grain

Disponibili per / available for / disponibles pour: K105 - PROFILE COLLECTION - FRAME 5.0 - FRAME 1.5 - T70 - T80

LARICE LARCH / MÉLÈZE



573 Larice amber



574 Larice arcite

Disponibili per / available for / disponibles pour: K105 - PROFILE COLLECTION - T70 - T80

NOCE CANALETTO WALNUT / NOYER

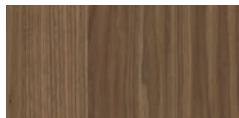

395 Noce canaletto

Disponibili per / available for / disponibles pour: K105 - PROFILE COLLECTION - T70 - T80

Sp. 23 mm



Venatura verticale
Veinure verticale
Vertical grain

Sp. 23 mm



Venatura verticale
Veinure verticale
Vertical grain

PET OPACO MATT PET / PET MAT

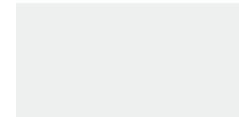

310 Bianco artico



311 Grigio pietra

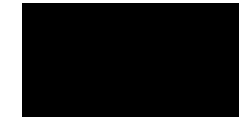

312 Nero

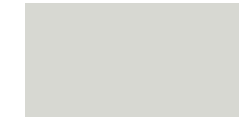

313 Sahara



314 Sand



315 Verde salvia

Disponibili per / available for / disponibles pour: K105 - PROFILE COLLECTION

PET LUCIDO GLOSSY PET / PET BRILLANT

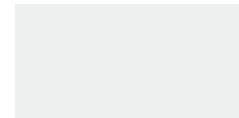

320 Bianco lux

Disponibili per / available for / disponibles pour: K105 - PROFILE COLLECTION

PET METAL METAL PET / PET METAL



330 Brunito



331 Bronzo



332 Blond

Disponibili per / available for / disponibles pour: K105 - PROFILE COLLECTION

Sp. 22 mm

Sp. 22 mm

Sp. 22 mm

FENIX NTM FENIX NTM / FENIX NTM

Sp. 22 mm



009 Bianco kos *



018 Bianco dover



003 Beige luxor

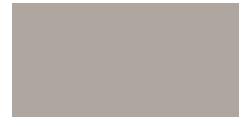

013 Beige arizona *



005 Castoro ottawa

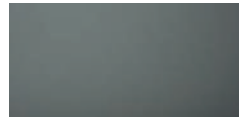

015 Verde comodoro

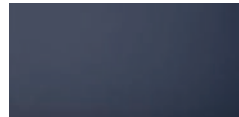

016 Blu fes

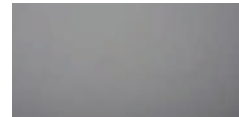

014 Grigio antrim

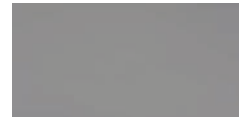

010 Grigio efeso *



006 Grigio londra *

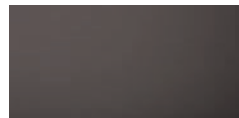

012 Cacao orinoco



011 Grigio bromo

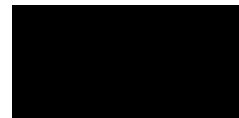

008 Nero ingo *

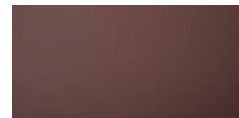

017 Rosso jaipur

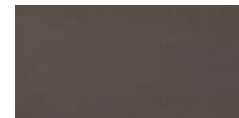

020 Bronzo doha *

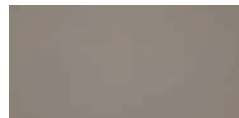

019 Zinco doha *



022 Titanio doha



021 Piombo doha

Disponibili per / available for / disponibles pour: K105 - PROFILE COLLECTION

*Disponibili per / available for / disponibles pour: T80 - T70

FENIX NTA FENIX NTA / FENIX NTA

Sp. 22 mm



023 Acciaio hamilton

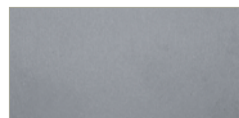

024 Argento dukat

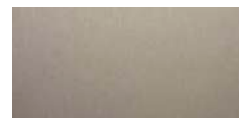

025 Oro cortez

Disponibili per / available for / disponibles pour: K105 - PROFILE COLLECTION - T70 - T80

LAMINATO BORDO UNICOLOR

UNICOLOR EDGE LAMINATE / STRATIFIÉ CHANT UNICOLOR

Sp. 22 mm



550 Impero *

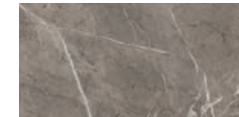

551 Keope



552 Tabak *

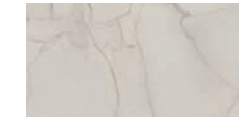

553 Perlino

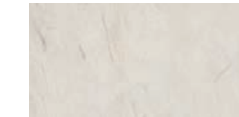

554 Himalaya



55C Sahara noir *



556 Statuario



55F Veneziano *



55A Rox black *



55B Peltro *

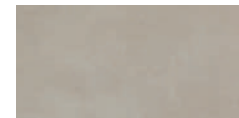

55E Rio bravo *

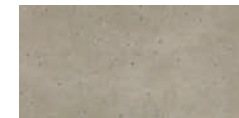

55D Olympus dionysus *

Disponibili per / disponibles pour / available for: K105 - PROFILE COLLECTION

*Disponibili per / disponibles pour / available for: T70

MELAMINICO TERMOSTRUTTURATO

THERMOSTRUCTURED MELAMINE / MÉLAMINÉ THERMO-STRUCTURÉ



103 Noce antico



587 Rovere paglia



588 Rovere duna



104 Rovere terra



176 Rovere alaska

Sp. 22 mm



Venatura verticale
Veinure verticale
Vertical grain

Disponibili per / available for / disponibles pour: K105 - PROFILE COLLECTION

MELAMINICO TINTA UNITA

MATT MELAMINE / MÉLAMINÉ MAT

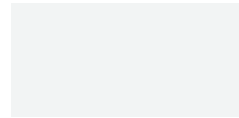

001 Bianco



055 Grigio cenere



056 Tanno



057 Terra di Siena



058 Grigio fumo



003 Tortora



002 Grigio onice

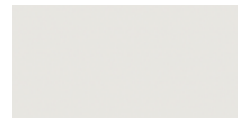

079 Mandorla



060 Verde tundra

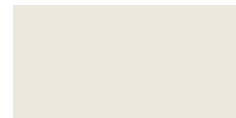

004 Deserto



083 Grafite liscio

Sp. 22 mm

Disponibili per / available for / disponibles pour: K105 - PROFILE COLLECTION

MELAMINICO EFFETTO LEGNO

WOOD EFFECT MELAMINE / MÉLAMINÉ EFFET BOIS



066 Quercia farro



111 Sbalzo farro



064 Quercia caffè



110 Sbalzo caffè



068 Noce biondo

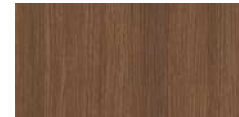

102 Quercia malto



067 Quercia juta

Sp. 22 mm



Venatura verticale
Veinure verticale
Vertical grain

Disponibili per / available for / disponibles pour: K105 - PROFILE COLLECTION

MELAMINICO EFFETTO MATERICO

MATERIAL EFFET MELAMINE / MÉLAMINÉ EFFET STRUCTURÉ

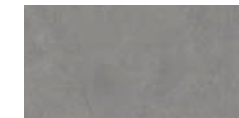

167 Calce silver



168 Calce brown

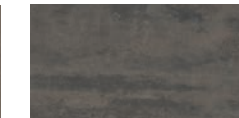

169 Ossido corten

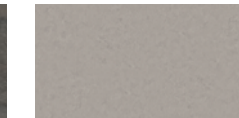

101 Rasato arena

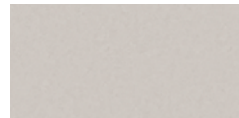

100 Rasato orzo

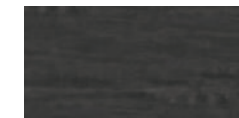

069 Metal grey



070 Metal brown

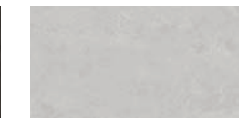

071 Ossido ghiaccio



072 Pietra baltica



082 Bruno



081 Ghisa



080 Nikel

Sp. 22 mm

Disponibili per / available for / disponibles pour: K105 - PROFILE COLLECTION

LACCATO OPACO MATT LACQUERED / LAQUE MAT

Sp. 22 mm

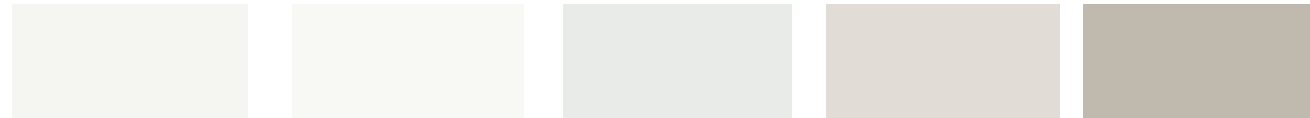

725 Bianco Light 750 Bianco Latte 705 Ghiaia 751 Camelia 742 Soia



702 Sabbia 703 Corda 752 Cashmere 753 Gianduia 743 Camoscio



754 Fondente 709 Piombo 748 Marsala 756 Anfora 730 Caramello



747 Corallo 755 Curcuma 732 Muschio 757 Alloro 744 Artico



731 Danubio 758 Nebbia 710 Antracite 729 Roccia 759 Nero assoluto



980 Opaco a Campione
980 Opaque to Sample
980 Opaque Selon Échantillon

Disponibili per / available for / disponibles pour: K105 - PROFILE COLLECTION - FRAME 5.0 - FRAME 1.5 - T70 - T80

Disponibili per / available for / disponibles pour: PLYSSÉ K105 - PROFILE COLLECTION

LACCATO LUCIDO GLOSSY LACQUERED / LAQUE BRILLANT

Sp. 22 mm

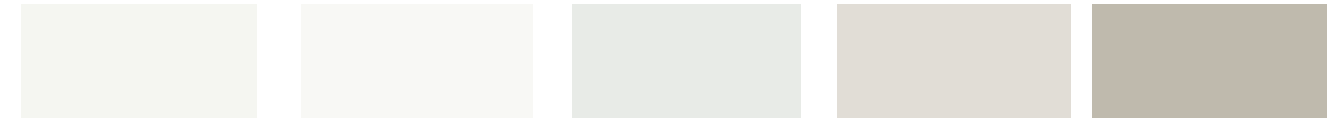

725 Bianco Light 750 Bianco Latte 705 Ghiaia 751 Camelia 742 Soia



702 Sabbia 703 Corda 752 Cashmere 753 Gianduia 743 Camoscio



754 Fondente 709 Piombo 748 Marsala 756 Anfora 730 Caramello



747 Corallo 755 Curcuma 732 Muschio 757 Alloro 744 Artico



731 Danubio 758 Nebbia 710 Antracite 729 Roccia 759 Nero assoluto



980 Opaco a Campione
980 Opaque to Sample
980 Opaque Selon Échantillon

Disponibili per / available for / disponibles pour: K105 - PROFILE COLLECTION

YOUNG COLLECTION

MELAMINICO OPACO YOUNG YOUNG MATT MELAMINE / MÉLAMINÉ MAT YOUNG

Sp. 19 mm



074 Bianco luna



075 Corda



073 Avana

Disponibili per / available for / disponibles pour: TIFFANY - CLOË COLLECTION

LACCATO OPACO YOUNG

YOUNG MATT LACQUERED MELAMINE / MÉLAMINÉ LAQUE MAT YOUNG

Sp. 19 mm

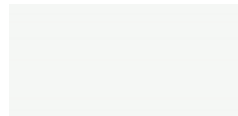

504 Bianco nuvola matt



512 Sandalo matt



513 Verde malga matt



514 Ghisa matt



507 Nero assoluto matt

Disponibili per / available for / disponibles pour: TIFFANY - CLOË COLLECTION

LACCATO LUCIDO YOUNG

YOUNG GLOSSY LACQUERED MELAMINE / MÉLAMINÉ LAQUE BRILLANT YOUNG

Sp. 19 mm

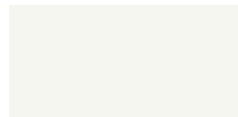

508 Bianco ghiaccio brill



515 Sandalo brill

Disponibili per / available for / disponibles pour: TIFFANY - CLOË COLLECTION

YOUNG COLLECTION

MELAMINICO EFFETTO LEGNO YOUNG YOUNG WOOD EFFECT MELAMINE / MÉLAMINÉ EFFET BOIS YOUNG

Sp. 19 mm



078 Rovere celtico



077 Rovere canapa

Disponibili per / available for / disponibles pour: TIFFANY - CLOË COLLECTION



Venatura verticale
Veinure verticale
Vertical grain

ROVERE YOUNG

YOUNG VEINED OAK / CHÊNE VEINÉ YOUNG

Sp. 19 mm



540 Rovere fiammato
ambra

Disponibili per / available for / disponibles pour: TIFFANY - CLOË COLLECTION

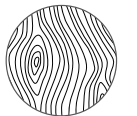

Venatura verticale
Veinure verticale
Vertical grain



Zecchinon è presente in tanti paesi del mondo, oltre a una distribuzione consolidata sul territorio italiano, si aggiunge un network internazionale in continua crescita che comprende circa 300 negozi nel mondo. All'interno di questa rete si aggiungono i negozi monomarca che rappresentano nel mondo la filosofia Zecchinon.

The company is now present in many countries around the world: in addition to the consolidated distribution in Italy, we created an international network of about 300 shops around the world, which is continuously growing. This network also includes flagship stores that represent the Zecchinon philosophy in the world.

Zecchinon est présent dans plusieurs pays dans le monde : outre à une distribution consolidée sur le territoire italien, on ajoute un réseau international qui continue d'augmenter et qui comprend 300 magasins dans le monde. À l'intérieur de ce réseau on ajoute les magasins mono marque qui représentent dans le monde la philosophie Zecchinon.

ZECCHINON CUCINE si riserva il diritto di apportare, senza preavviso, ogni modifica mirata al miglioramento funzionale e qualitativo dei propri prodotti. Testi e disegni presenti in questo stampato hanno scopo divulgativo: per ogni aspetto tecnico e dimensionale fare riferimento ai listini aziendali e relativi aggiornamenti. I campioni di colori e materiali hanno valore indicativo.

PER AGGIORNAMENTI RELATIVI ALLE FINITURE CONSULTATE SEMPRE IL NOSTRO SITO
WWW.ZECCHINON.IT

ZECCHINON CUCINE reserves the right to make without notice any changes aimed at improving the functions and qualities of its products. The texts and drawings in this publication are purely for advertising purposes: for technical and dimensional aspects consult the company price lists and updates. Colour and material samples are indicative.

FOR UPDATES ON MATERIALS AND FINISHES, ALWAYS VISIT OUR WEBSITE WWW.
ZECCHINON.IT

ZECCHINON CUCINE se réserve le droit d'apporter, sans préavis, toute modification destinée à l'amélioration fonctionnelle et qualitative de ses produits. Les textes et les dessins présents dans cet imprimé sont divulgués à titre informatif: pour tout aspect technique et de dimension, se référer aux listes d'entreprise et leurs mises à jour correspondantes. Les échantillons de couleur et les matériaux ont une valeur indicative.

POUR DES MISES A JOUR CONCERNANT DES MATERIAUX ET DES FINITIONS CONSULTEZ
TOUJOURS NOTRE SITE WWW.ZECCHINON.IT

Design
Zecchinon R&D + Haften Studio

Art Direction and Graphics
Haften Studio

Virtual images
Neiko

Print
Grafiche Italprint

ZECCHINON CUCINE srl
Via Castello, 133
31020 - Sernaglia della Battaglia (TV)
ITALIA
tel +39 0438 860341
www.zecchinon.it



100%
MADE
IN
ITALY

ZECCHINON

zecchinon.it